

## 86HS Series 2 Phase Hybrid closed loop Stepper Motors

### General Specifications

Item	Specification
Step Angle Accuracy	± 5% (whole step )
Resistance Accuracy	± 10% (20°C)
Inductance Accuracy	± 20% (1KHZ)
Temperature Rise	80°C max (Rated current, 2-phase power)
Ambient Temperature	-20°C ~ +50°C
Insulation Resistance	100M Ω Min 500 VDC
Dielectric Strength	500V AC 1 minute
Allowable Radial Load	0.02mm Max (450g load)
Allowable Thrust Load	0.08mm Max (450g load)
Radial maximum load	130N (From the flange surface 20mm)
Axial maximum load	30N



相数 2Phase

CE RoHS

### Specifications

Model	Step angle (°)	Motor length (mm)	Holding torque (N.M)	Current (A/phase)	Rotor inertia (g.cm <sup>2</sup> )	NO of encoder lines (PPR)	Resistance (Ω/phase)	Inductance (MH/phase)	Weight (kg)
LC86H260	1.8	60+22	3.0	6.0	1100	1000	0.3	1.6	2.0
LC86H268	1.8	68+22	3.5	6.0	1400	1000	0.3	2.2	2.2
LC86H280	1.8	80+22	4.5	6.0	1800	1000	0.3	3.4	2.5
LC86H298	1.8	98+22	6.5	6.0	2800	1000	0.5	4.3	3.3
LC86H2120	1.8	120+22	8.2	6.0	3600	1000	0.5	6.5	4.0
LC86H2128	1.8	130+22	10	7.5	4200	1000	0.4	4.6	4.5
LC86H2160	1.8	156+22	12	7.5	5400	1000	0.5	6.3	5.4

The above is only for representative products, We can according to customer requirements to remake.

### Dimensions:

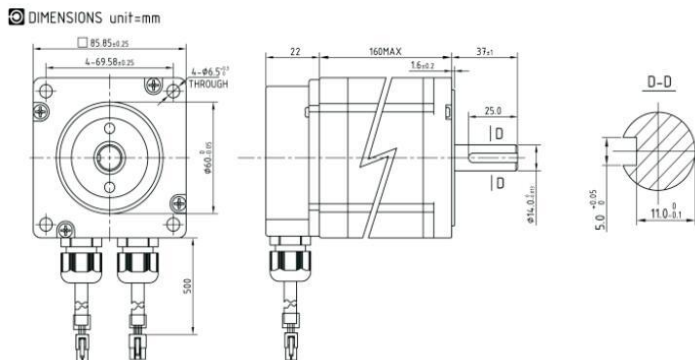

### Motor Shaft :

Item	Shaft (mm)	Axis stretch (mm)	Axis length (mm)
LC86H260	14	Flat Key 5x5x25	37
LC86H268	14	Flat Key 5x5x25	37
LC86H280	14	Flat Key 5x5x25	37
LC86H298	14	Flat Key 5x5x25	37
LC86H2120	14	Flat Key 5x5x25	37
LC86H2128	14	Flat Key 5x5x25	37
LC86H2160	14	Flat Key 5x5x25	37

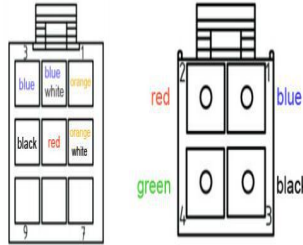
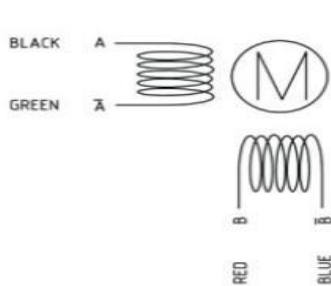
**Wiring Diagram:**
**MOTOR CONNECTIONS**

1	Black	EGND
2	Red	+5VCC
3	Blue/ white	EA-
4	Blue	EA+
5	Orange/ White	EB-
6	Orange	EB+

**Note:**

1. Do not connect the motor to the driver.
2. Due to different driving conditions, the motor may have a significant fever situation.  
The surface temperature of the motor is allowed to exceed 85 ° C during operation.
3. When installing the motor, be sure to use the front end cover of the motor to install the nozzle only, and pay attention to the tolerance, to ensure the concentricity between the motor shaft and the load.