

Dimensions

unit=mm

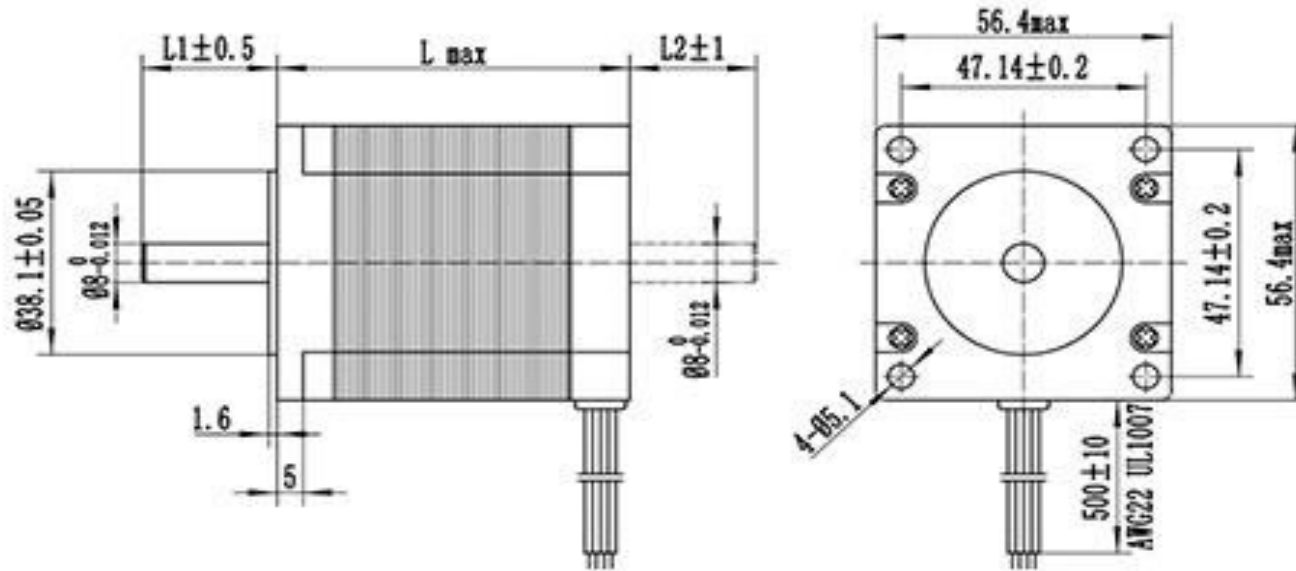

Wiring Diagram:

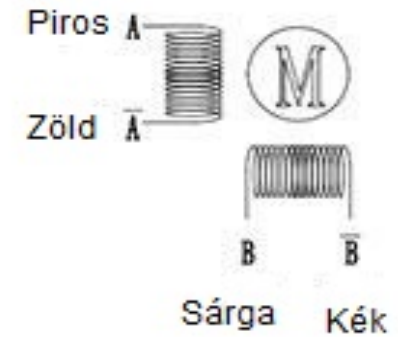

4 Leads

Model No	Step Angle (°)	Rated Voltage (V)	Rated Current (A)	Phase Resistance (Ω)	Phase Inductance (mH)	Holding Torque (Nm)	Detent Torque (g.cm Max)	Rotor Inertia (g.cm ²)	Motor Length (mm)	Leads No.	Motor Weight (Kg)
57JS51-2504	1.8	1.1	2.5	0.9	1.5	1.0	680	480	51	4	0,5