

DM442-IO-24 2-phase Speed Control Stepper Drive

20-40VDC, 0.5-4.2A peak current, Auto-configuration, Low Noise

Features

- External I/O signal control mode, with 24VDC
- DIP switch setting drive's output current and motor speed
- PUL+ and PUL- signals indicate Start and Stop
- DIR+ and DIR- signals indicate motor running direction
- Auto-tuning
- Matched with NEMA 17, 23, 24 stepper motors

Power Supply Connection

- Rang 20-40VDC, recommend 24-36VDC power supply, higher power voltage brings better performance at high speed.
- Pay attention to polarity of power, otherwise, the drive will burn out.

DM442-IO-24 Size (unit: mm)

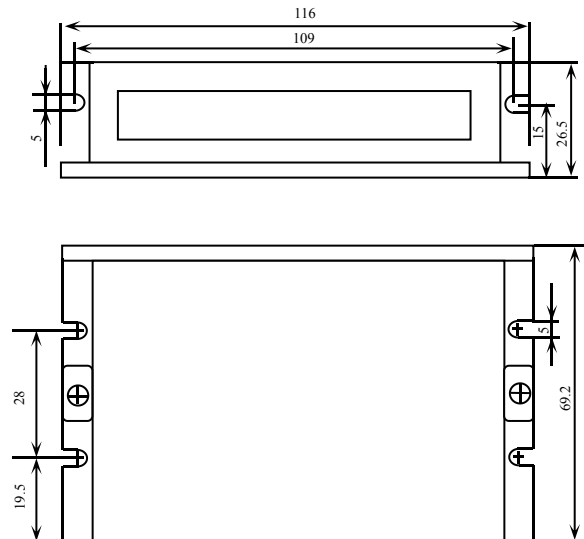

I/O Signals Connection

- The I/O signals connections are as below, PUL signals indicate Start/Stop function, DIR signals indicate motor running direction, ENA signals indicate lock the motor shaft (no need to be connected by default)
- Control signals voltage is 24VDC.

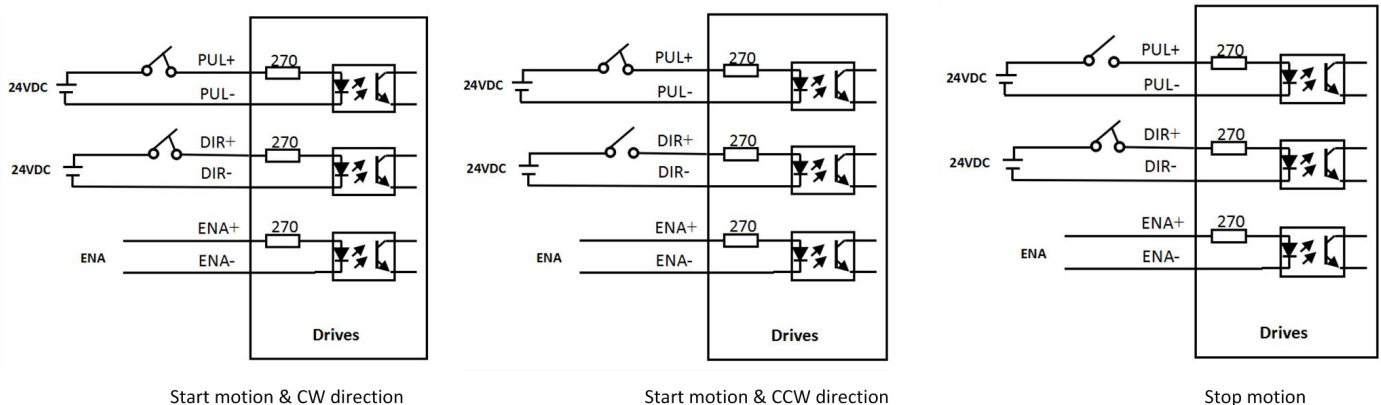

Motor Connection

- DM442-IO-24 can match with Leadshine 2-phase stepper motor, size include NEMA14, 23, 24
- The motor connections are shown as below

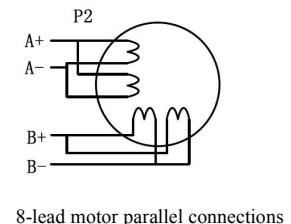
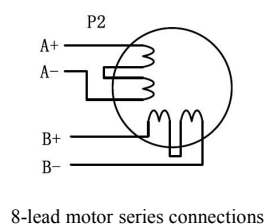
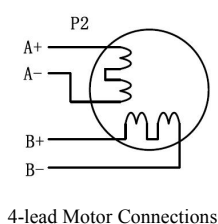

DIP Switch Setting

- DM442-IO-24 has 8-bit DIP switches, functions as below:

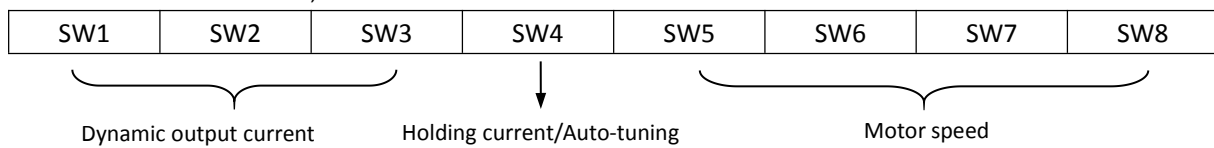

- Output current setting (3-bit)

Peak	RMS	SW1	SW2	SW3
Default		on	on	on
1.46A	1.04A	off	on	on
1.91A	1.36A	on	off	on
2.37A	1.69A	off	off	on
2.84A	2.03A	on	on	off
3.31A	2.36A	off	on	off
3.76A	2.69A	on	off	off
4.20A	3.00A	off	off	off

- Motor speed setting (4-bit)

Motor Speed (RPM)	SW5	SW6	SW7	SW8
50	on	on	on	on
150	off	on	on	on
250	on	off	on	on
350	off	off	on	on
450	on	on	off	on
550	off	on	off	on
650	on	off	off	on
750	off	off	off	on
850	on	on	on	off
950	off	on	on	off
40	on	off	on	off
60	off	off	on	off
70	on	on	off	off
80	off	on	off	off
90	on	off	off	off
100	off	off	off	off

- Holding current/Auto-tuning (SW4)

“Off” means holding current is 60% of dynamic current, while “on” means 100%.

Switch “SW4” two times in two seconds will activate parameter Auto-configuration for current loop.

Note: This drive is only suitable for long-term constant speed applications, not for applications with frequent speed adjustment.



Be sure to read this manual carefully before trying to install and use the product.

Be sure to check the connections and make sure the power lead polarity is correct, or there could result in injury or fire.

Be sure to ground the earth terminal of the motor and drive without fail, or there could result in electrical shock.

Be sure to mount the load after making sure the motor work well without load, or there could result in some accident.

Be sure to turn off power and wait for 10 minutes or longer after LED display of the front panel has gone off, and then you can transporting, wiring and inspecting the drive, or there could result in electrical shock or fire.

Be sure to install an emergency stop circuit externally so that you can stop the operation and shut off the power immediately, or there could result in some accident.

Be sure to give the power supply voltage does not exceed the drive’s input range, or there could result in burning out drive and motor.

Web: <http://www.leadshine.com>

Sales: sales@leadshine.com

Support: tech@leadshine.com